

University of Mississippi

eGrove

---

Open-File Reports

Mississippi Mineral Resources Institute

---

1987

## Evaluation of An Electrostatic Separator for Ultrafine Grind Lignite

Charles Bouchillon

Glenn Steele

Follow this and additional works at: [https://egrove.olemiss.edu/mmri\\_ofr](https://egrove.olemiss.edu/mmri_ofr)

---

### Recommended Citation

Bouchillon, Charles and Steele, Glenn, "Evaluation of An Electrostatic Separator for Ultrafine Grind Lignite" (1987). *Open-File Reports*. 116.

[https://egrove.olemiss.edu/mmri\\_ofr/116](https://egrove.olemiss.edu/mmri_ofr/116)

This Report is brought to you for free and open access by the Mississippi Mineral Resources Institute at eGrove. It has been accepted for inclusion in Open-File Reports by an authorized administrator of eGrove. For more information, please contact [egrove@olemiss.edu](mailto:egrove@olemiss.edu).

Open-File Report 87-4F

Evaluation of An Electrostatic Separator  
For Ultrafine Grind Lignite

Dr. Charles W. Bouchillon  
Dr. W. Glenn Steele

1987

The Mississippi Mineral Resources Institute  
University, Mississippi 38677

EVALUATION OF AN ELECTROSTATIC  
SEPARATOR FOR ULTRAFINE GRIND LIGNITE

by

C. W. Bouchillon  
W. G. Steele

Submitted to

Mississippi Minerals Resources Institute  
University, MS

Submitted by

Mechanical and Nuclear Engineering Department  
Mississippi State University  
Mississippi State, MS 39762

July 31, 1987

This work partially sponsored by MMRI Grant No. 87-4F and the U. S. Bureau  
of Mines Allotment Grant No. G1164128.

TABLE OF CONTENTS

	Page
1 .0 Summary .....	1
2 .0 Background Information .....	3
2.1      ReviewofResearchon    Low Rank Coal Processes	.3
2.2      ReviewofResearchon    Ultrafine Grinding .....	6
2.3      ReviewofResearchon    Coal Cleaning .....	9
3 .0 Objective .....	18
4 .0 Detailed Design of the Apparatus .....	18
5 .0 Experimental Evaluation .....	21
6 .0 Conclusions and Recommendations .....	21
7 .0 References .....	22

## ACKNOWLEDGMENTS

The authors wish to thank the MMRI for the opportunity to pursue this work through partial support provided by MMRI Grant No. 87-^F and the U. S. Bureau of Mines Allotment Grant Number G11641 28. Thanks are also due to Mrs. Teressa Yeatman for assistance in the preparation of this report and to Mr. Bob Gallik for assistance in fabrication of the laboratory scale system..

## LIST OF FIGURES

<u>Figure</u>	<u>Description</u>	<u>Page</u>
1	Comparison of Streamlines for Conventional and Micropulverized Ash	4
2	Description of Fluid Energy Mill - Elevation	10
3	Description of Fluid Energy Mill - Plan	10
4	Description of Fluid Energy Mill - Jet Details	10
5	Concept Sketch for Electrostatic Separator	17
6	Concept Sketch for Electrostatic Separator - Lab Scale Apparatus	17
7	Cross Section Detail Sketch for Electronic Separator	19
8	Sketch of Electrostatic Separator System	20

EVALUATION OF AN ELECTROSTATIC SEPARATOR  
FOR ULTRAFINE GRIND LIGNITE

1.0 SUMMARY

Most low-rank coals in the Northern Great Plains and Powder River basin contain less than 10% ash on an as-received basis. Lignites from the Gulf Coast may contain up to 30% ash. It has been well documented that ash in these coals occurs as organically bound inorganics and as finely divided minerals which are dispersed throughout the coal structure. Consequently burning some of these coals in conventional power plants may result in slagging of furnace walls and added cost of pollution abatement equipment.

Advanced utilization applications such as turbines, diesels, or retrofit coal burning systems to replace oil or gas require a coal containing less than .2% extraneous ash. All coals will require some form of wet or dry fine cleaning in order to meet these specifications. Also, savings may result in conventional pulverized coal systems if the coal is cleaned prior to burning.

Coal cleaning by dry methods have special appeal where coal is utilized as dry solids since moisture removal after treatment and water pollution control is not required. Utilizing the differences in electrostatic properties of coal and minerals is not commercially available but is one potential dry method. This method depends on the deflection of small particles by an electrical field with the positively charged particles moving in the direction of the field while the negatively charged particles move in the opposite direction.

A key factor in this process is applying a charge to the particles by methods such as triboelectrification. The principle of this phenomenon is that when two particles of dissimilar composition or structure are in physical contact, electrical charge is transferred. If one of the particles is a semiconductor or an insulator, upon separation, one particle will remain positively charged and the other negatively charged.

A procedure which utilizes triboelectrification for separation of minerals from coal reported in the literature is the electrostatic tower. The principle of the electrostatic tower is that charged coal particles fall between charged plates, with the result that different components of the coal are deflected from free fall based their on electrostatic properties. The coal is separated into ash rich and ash lean fractions.

A different design for the electrostatic separation process for triboelectrified particles of differential charges has been used for this project. The basic process is to provide a stable flow condition of a clean inert gas into which the differentially charged particles will be discharged. This centrally loaded slurry will then pass through a high gradient electrostatic field with the differentially charged particles being carried in opposite directions from the center by the resultant electrostatic forces.

The ash rich and the coal rich fractions are then passed through a solids separator in order to strip out the solids, while allowing the inert gas to be recirculated. A laboratory scale experimental apparatus has been designed and fabricated to evaluate this concept.



The resulting ultrafine product from a cleaning process can be used in the powder form or can be slurried for use in oil or natural gas boilers.

## 2 .0 BACKGROUND INFORMATION

### 2.1. Review of Research on Low Rank Coal Processes

Lignite has been mined and utilized as a boiler fuel on a regional basis for several years, primarily in North Dakota and Texas. The major U. S. lignite deposits occur in the Fort Union Region (North Dakota and Montana) and the Gulf Region (Texas, Louisiana, Arkansas, Tennessee, Mississippi, and Alabama) [1,2]. The Gulf Coast lignite resources have been estimated at thirty-five billion tons with the majority of this in Texas and Mississippi [3L

Related work on ultrafine pulverized coal [4,5] has shown that micropulverized coal (100% less than 44 microns) will cause less slagging than conventional pulverized coal when used in an oil or gas boiler. Figure 1, similar to the illustration presented by Marguiles, et.al. [4], illustrates the basic concept favoring ultrafine grinding. Other work on slag reduction of Canadian lignites has been reported E6J. The tubes in oil and gas boilers are generally spaced closer than those in conventional coal-fired boilers. Because of this increased tube surface to flow/ area ratio, the larger ash particles in conventional pulverized coal will impact the tubes and cause slagging. However, the very fine ash particles in the micropulverized coal or lignite tend to follow the flow streams around the tubes resulting in less slagging and erosion. These small particles can then be collected by a scrubber, a baghouse, or a precipitator.

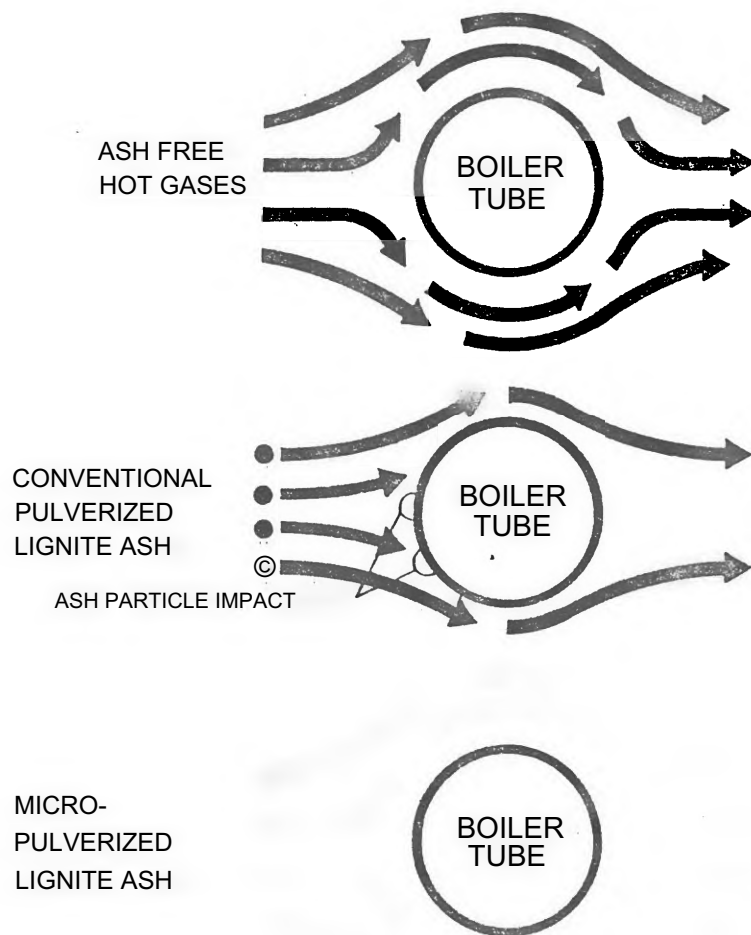

Figure 1.

COMPARISON OF  
GAS STREAMLINES  
AND ASH TRAJECTORIES  
WHEN FIRING  
CONVENTIONAL  
VS.  
MICROPULVERIZED  
LIGNITE

An oil or water slurry is one of the primary methods being considered for transport and end use of pulverized coal. With regular pulverized coal slurries, either the boiler must be modified to minimize fouling or the coal must be beneficiated to reduce the ash content. The coal slurry technology is progressing at a rapid rate and preliminary commercialization efforts are underway [7,8,9].

Work has been performed in Australia on the use of ultrafine grind brown coal to make a coal-oil mixture to replace diesel fuel for engines [10]. Also ultrafine grind coal-oil mixtures made by Ergon, Inc. have been successfully burned with no significant ash deposits forming in the boiler [11].

The primary result of the pulverization tests conducted previously was that lignite with its high moisture content could be ultrafine ground. The fluid-energy mill used for ultrafine grinding is described by Taylor [12]. Basically, a ring of inward facing jets directed slightly off-center causes a vortex flow to be established and the particles grind or impact against each other to generate a pulverized product with a mean diameter of 15 to 25 microns based on volume.

When superheated steam is used as the grinding fluid, there is a permanent drying effect on the lignite. Work on steam and hot water drying processes that accomplish a permanent drying of lignite are described in detail [13,14] for North Dakota lignites. The results of these studies show that if the lignite is heated to a temperature of about 310°C for 15 minutes, the inherent moisture reabsorbed will be only about 10 percent as compared with the 35 percent for the original lignite used in the studies. It was also found that temperatures greater than 310°C have only a small additional drying effect.

Comparison of the ash characteristics of various lignites was presented by White E15]. The Gulf Coast lignites generally have a much higher silicate content and a significantly lower sodium content than the North Dakota lignites. This suggests that a mechanical or physical separation process may be more important than a chemical or ion-exchange for the Gulf Coast lignites.

Previous work in gravimetric methods applied to ultrafine grind coals indicated that hydrocyclones may be effective for ash removal. The results are highly dependent upon the washability--or the ash distribution with specific gravity. Recent work by Keller and Simmons E16] indicates that for coals with good washability characteristics, that good cleaning of -325 mesh coal in a true heavy liquid medium of Freon-113 can be accomplished in a 2 inch cyclone with an 85 psi pressure drop. Washability studies E17] indicate that some Gulf region lignites do have reasonably good washability characteristics while some exhibit almost no ash content variation with specific gravity.

In an effort to reduce the sodium content of North Dakota lignites Paulson, et.al. [18] have done extensive work in ion-exchange processes which result in a reduction in the sodium content of the ash--apparently the predominant ash component contributing to tube fouling problems in boilers.

## 2.2. Review of Research on Ultrafine Grinding

### 2.2.1 Introduction

Ultrafine grind coal or lignite is typically defined as a pulverized product with a particle size distribution which is ninety-eight percent less than 325 mesh. Such products can be

produced with either mechanical or fluid-energy pulverizers. Depending on the operating parameters of the pulverizer, the pulverized coal can have a mean particle size based on population ranging from 2 to 10 microns.

There has been limited work done on ultrafine grind lignites. Bouchillon and Steele have conducted limited research on the ultrafine grinding of Mississippi lignite in a fluid-energy mill [19 and 20]. They have also investigated a Texas lignite [21]. The initial results have shown that lignite, even with its high moisture content, can be ultrafine ground to a mean diameter based on volume of 15 to 25 microns. In-the-mill drying tests have also been conducted with preliminary results showing that some permanent drying of the lignite can be accomplished.

Ultrafine grinding of coal or lignite can be accomplished with either mechanical or fluid-energy mills. Mechanical units of the ball type or the ball-and-race type can be downrated to produce an ultrafine grind product. The problem with this type of grinder is the excessive wear which results from the friction between the grinding surface and the lignite. The largest commercial mechanical units available are reportedly capable of about eight tons per hour when grinding coals to an ultrafine size.

Fluid-energy mills are available in either the impact type or the vortex-shear type. These mills have the advantage of minimum mechanical wear. Units of the vortex-shear type are available with capacities up to 20 tons per hour.

### 2.2.2 Methods to Produce Ultrafine Coal

As noted above, fluid-energy mills are available in either the direct impact or vortex-shear types. The impact version uses two opposing jets of coal/lignite and steam or inert gas in the impact zone. The particles impact and break into finer particles. This product is then circulated through the plant classifier which removes the particles that are less than 325 mesh and sends the larger particles back to the impact zone.

Two major manufacturers of the impact mills are Farrier, Inc. and Donaldson Co., Inc. The Farrier mill, called a COJA mill, has an advertised capacity of 7.5 tons per hour with the scale-up to a 20 ton per hour mill considered feasible. The Donaldson mill, called a Majac Pulverizer, is very similar to the COJA mill in design and operation. Typical capacities given for bituminous coal for the Majac mill are 8,000 lbs/hr coal with 3000 SCFM of air at 100 psig and 70°F.

The vortex-shear type of pulverizers employ a more continuous grinding process than the impact grinders. The circulating product in the comminuting chamber grinds on itself with the larger particles staying in the grinder and the finer product escaping through the classifier.

The Sturtevant Micronizer is an example of a vortex-shear type unit. The grinding area is a circular chamber with a tangential feed input. The centrifugal force holds the oversized particles in the grinding area while the finer particles move toward the collection chamber in the center of the mill. The advertised capacity has an upper range of 2 tons per hour with 4 tons of steam per hour as the carrier fluid.

The mill used by Micro-Energy, an Ergon, Inc. company, is also of the vortex-shear type. This mill differs from the Sturtevant design in that the comminuting chamber has a larger volume which contains the vortex of air or steam and coal. A version of the Ergon pulverizer has been reportedly operated at 20 tons per hour of coal with an equal amount of steam or air as the driving fluid. This low ratio of fluid to coal along with the large capacity, makes the Ergon mill very attractive for commercial applications.

The patent for the Ergon mill was granted to David W. Taylor [12]. Schematic diagrams from the patent which show the operation of the pulverizer are given in Figures 2-4. Figure 2 shows how the cyclone forms in the chamber with the light particles migrating to the center and the heavy particles falling back to the bottom of the chamber. The coal feed enters from the top, and the final product passes around the classifier and out the unit as shown in Figure 3. Figure 4 shows how the vortex motion is generated with the opposing steam or air jets oriented at various angles around the base of the chamber.

## 2.3 Review of Research on Coal Cleaning

### 2.3.1 Wet Processes

In order to be able to burn coal in an existing plant without the addition of downstream exhaust gas treatment in the TVA Paradise Plant in Kentucky, TVA elected to build and operate a wet type coal cleaning plant for ash and sulfur removal prior to burning. This plant does reduce the sulfur and ash content of the coal stream, however, it is at considerable initial and operating expense. The water based coal

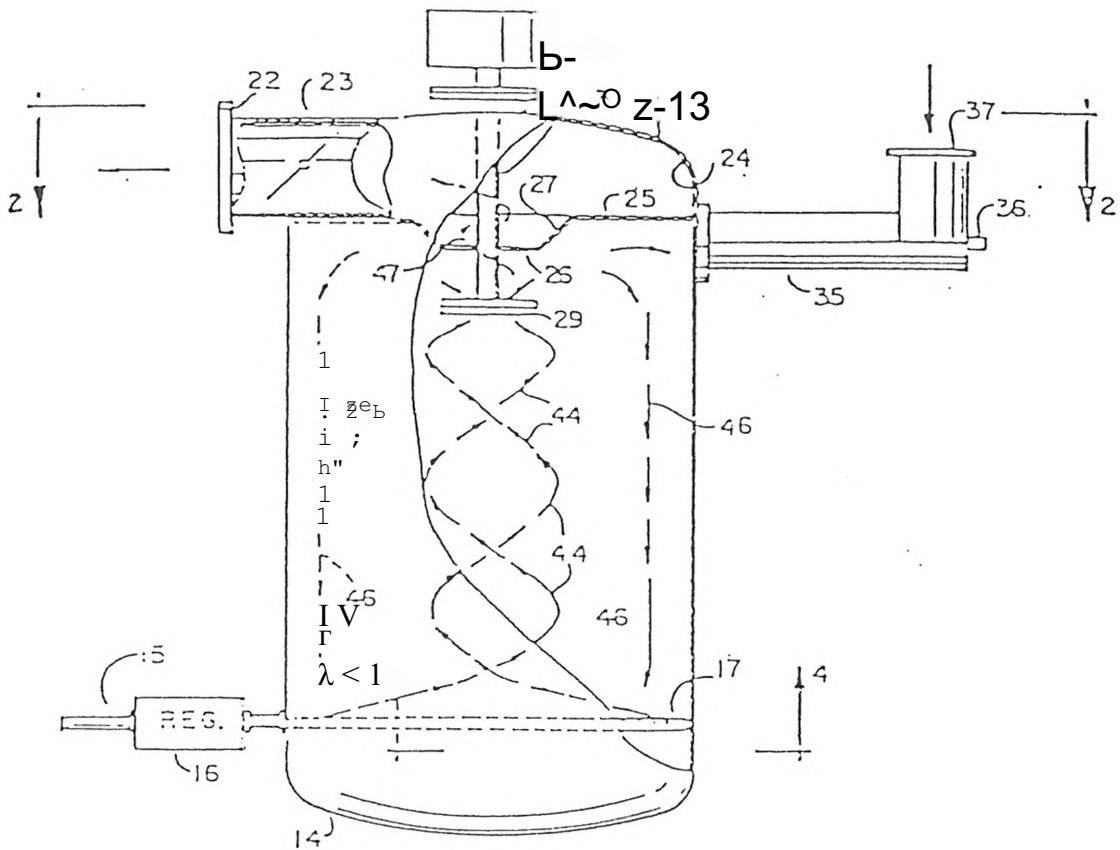

Figure 2.

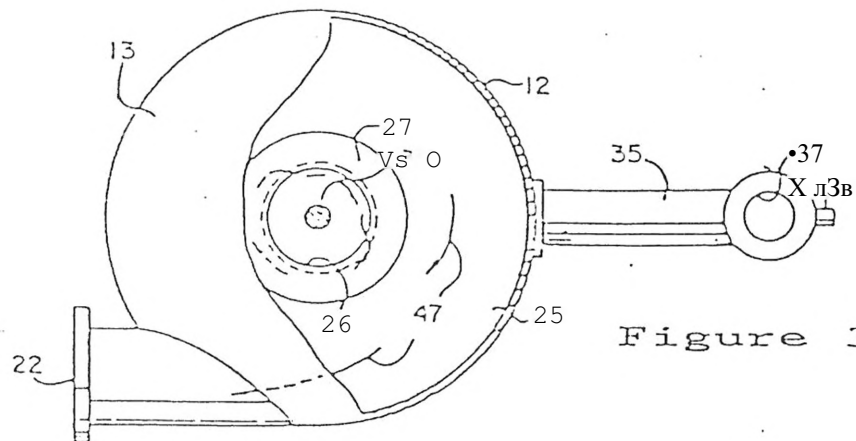

Figure 3.

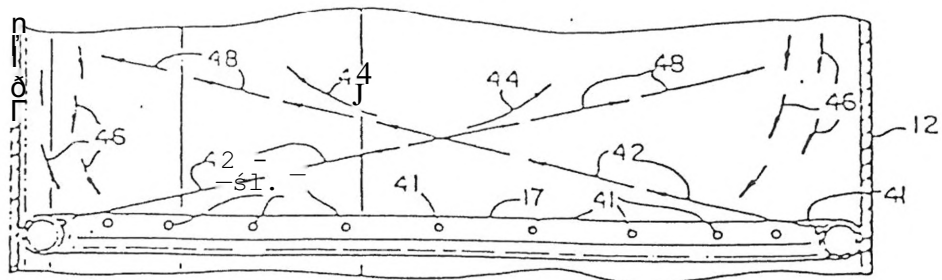

Figure 4.



cleaning system requires significant water treatment and the solids waste disposal is difficult because of the slimy nature of the reject's stream.

The proposed electrostatic separator system would have a dry rejects product stream and consequently would not present the grave difficulty of water treatment experienced by the TVA plant. The proposed system would also be less expensive for the initial costs based on very preliminary estimates. The pumping costs involved with the cleaning plant at TVA are also very significant in that the water streams sometimes go vertically for a distance of approximately 8 floor levels, thereby producing high static heads on the pumps. A facility for the proposed process would be on a single level probably no more than thirty feet high.

Oil agglomeration, froth floatation, and micro-bubble floatation are other wet processes which have been used successfully to clean finely ground bituminous coals.

### 2.3.2 Electrostatic Separation of Micropulverized Coal

#### 2.3.2.1 Introduction

Several techniques have been proposed for the electrostatic or magnetic separation of materials with different magnetic or electrostatic properties. Dry separation of pyrite from fine coal using a combination of centrifugal and electrostatic devices was reported by Abel, Zúlkoski, and Gauntlett [22]. With stage grinding, nearly 90 percent of the available pyritic sulfur was removed from a Pittsburgh seam coal.

(Carpco, Inc. has a line of electrostatic and high-intensity magnetic separators which may prove useful in some applications. High gradient magnetic separation for the removal of sulfur from coal has been discussed by Luborsky [23] and further work has been done by TVA and Oak Ridge National Laboratory.

Separation of non-magnetic metals from solid waste by dynamic application of permanent magnets was presented by Schlomann [24]. This method is based on the difference in electrical conductivity of the materials and may have some potential for coal cleaning because of the expected differences in the electrical conductivities of the coal and minerals.

It has been discovered that it may be possible to utilize the process of triboelectrification--the differential charging of particles due to frictional or impact effects--for the purpose of separation of ash rich particles from pulverized or micropulverized coal. Preliminary laboratory scale work has been accomplished on this process by Inculet [25], et.al. in Ontario Canada on Hat Creek coal in the fluidized state. In their work, the experimental apparatus was a continuous loop which had a divergent section serving as a diffuser approaching the test section. An attempt was made to provide for laminar flow in the test section. The particles were distributed throughout the incoming fluid stream into the diffuser section and consequently were distributed across the total test section.

A different physical configuration is proposed for electrostatic separation of a stream of micropulverized low rank coal being discharged from the Ergon, Inc. fluid energy ultrafine grinding system. This is described in detail below.

### 2.3.2.2 Description of the Proposed Process

The proposed process of electrostatic separation of an ash rich fraction from the stream of ultrafine grind coal coming from the fluid energy mill would consist of the following apparatus configuration. A sketch of a cross section of the proposed apparatus is presented as Figure 5. The operation would be as follows.

The material from the fluid energy mill would be admitted into a centrally located feed system equipped with turning vanes so as to direct the material downward into the test section. Turbulent flow conditions would be maintained in this section in order to maintain particle separation. The triboelectrification process which is expected to occur in the fluid energy mill would provide for a differential charge on the particles as they exit the mill. If these particles remain in turbulent flow conditions, then they should remain separated in spite of the resultant attractive electrostatic force which would exist between the particles.

In order to minimize the turbulence level in the test section of the electrostatic separator, the test or working section would consist of a convergent channel with charged plates on each wall. The convergent flow would be admitted through the plenum chamber shown at the top of Figure 5 and smoothed through the porous plate. The main body flow would then pass through the convergent test section and would be a very stable flow condition which would represent laminar type flow at Reynolds numbers higher than for a straight or divergent section. Also, the convergent walls would provide for electrostatic field forces

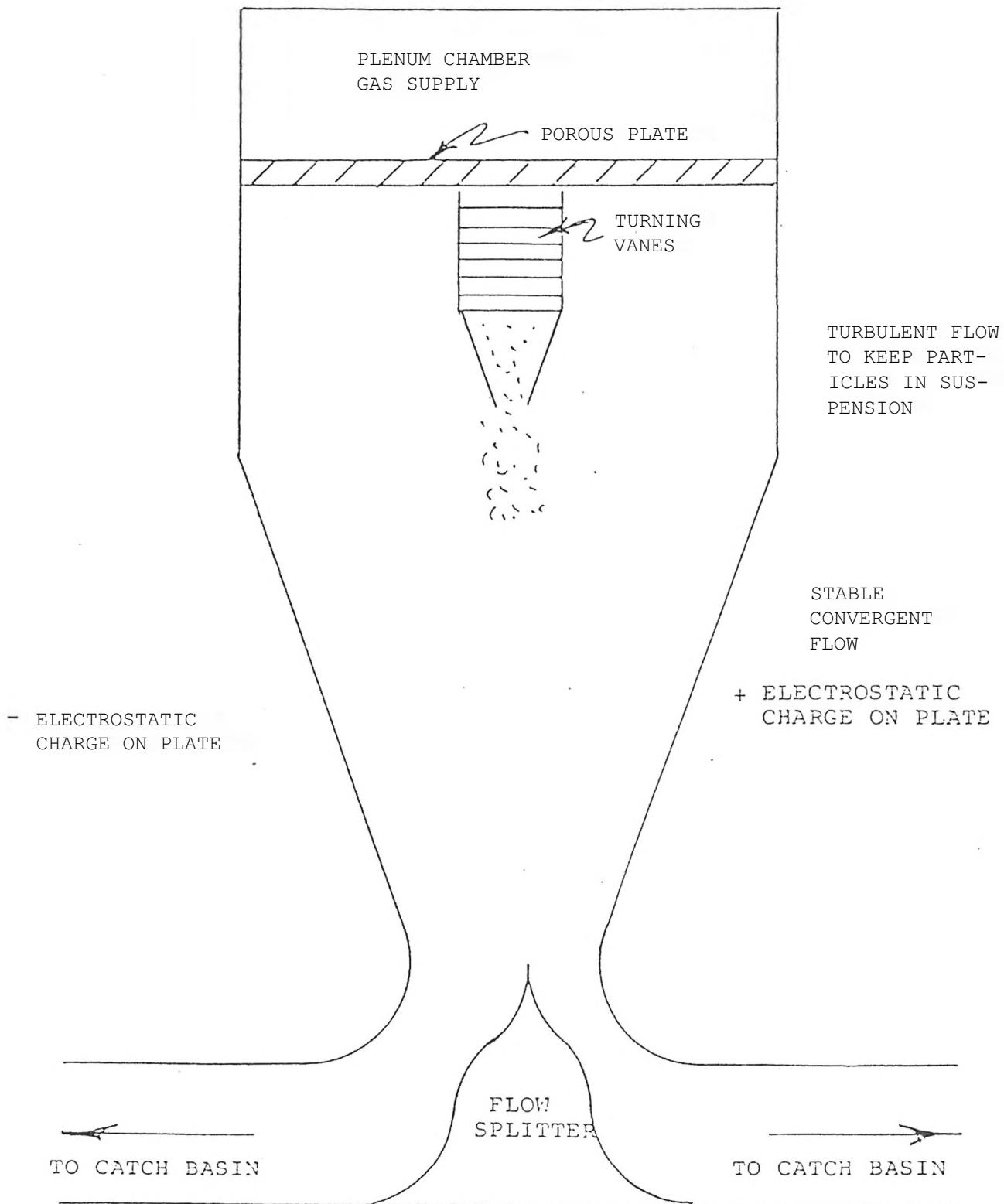

J Figure 5. Concept Sketch for Electrostatic Separator

on the differentially charged particles. The minor flow with the feed stream would be turbulent but would be absorbed and smoothed out in the main flow of the convergent test section.

The differentially charged particles would then experience a difference in electrostatic forces and have resultant different trajectories. These particles would approach the walls; however, it is expected that there would be sufficient boundary effects to prevent attachment to the walls. It may be appropriate to consider slightly roughened walls or porous walls with inwardly directed flows through them in order to prevent particle buildup on the walls. A wetted wall electrostatic precipitator has been used successfully in the removal of particulates from a recovery boiler in a paper mill. This concept may prove advantageous if the total process is to make a cleaned low rank coal/water slurry. This process was not considered for laboratory work proposed in this project, however, it may be of significant interest for a follow-on effort to design a Continuous Process Development Unit (CPDU) scale system. This system would provide for continuous flow "separation" and not "precipitation" as is the case for electrostatic fly ash precipitators .

A flow splitter is provided at the bottom of the convergent test section to allow different stream splits to be made in order to evaluate the separation effects of the electrostatic field on the particle stream.

Following the stream splitter, in the continuous process case, there would probably be air cyclone collectors installed in order to collect the particulates from the system. A blower could then be connected to the cleaned stream for recirculation of an inert gas such

as nitrogen if required. For early experimentation, it is appropriate to simply use a filter bag to simulate a baghouse. It may also be appropriate to consider a baghouse particulate removal system such as are being used on some ultrafine grind coal fired power plants for the ash collection system with the cleaned coal stream going directly to the burner.

#### 2.3.2.3 Description of the Laboratory Scale Test Apparatus

A description of the laboratory scale test apparatus is presented as Figure 6 in sketch form. A blower has been added to complete the nitrogen loop. A supply of nitrogen was originally used to provide jets in a mixing chamber to provide for triboelectrification of the particles.

A mechanical agitator has been installed in the mixing chamber to provide for better triboelectrification of the particles.

#### 2.3.2.4 Particle Trajectory Predictions

A first approximation to the electric field may be made by neglecting the presence of the particles and using a polar coordinate system. This electric field distribution is then available to use in conjunction with a particle trajectory prediction.

The particle trajectory analysis was predicted through solution of the equations of motion on a high speed digital computer similar to the approaches used by Bouchillon [26] and Boysan, et al. [27]. Nester [28] developed this analysis as a design project for a Master of Mechanical Engineering degree at MSU.

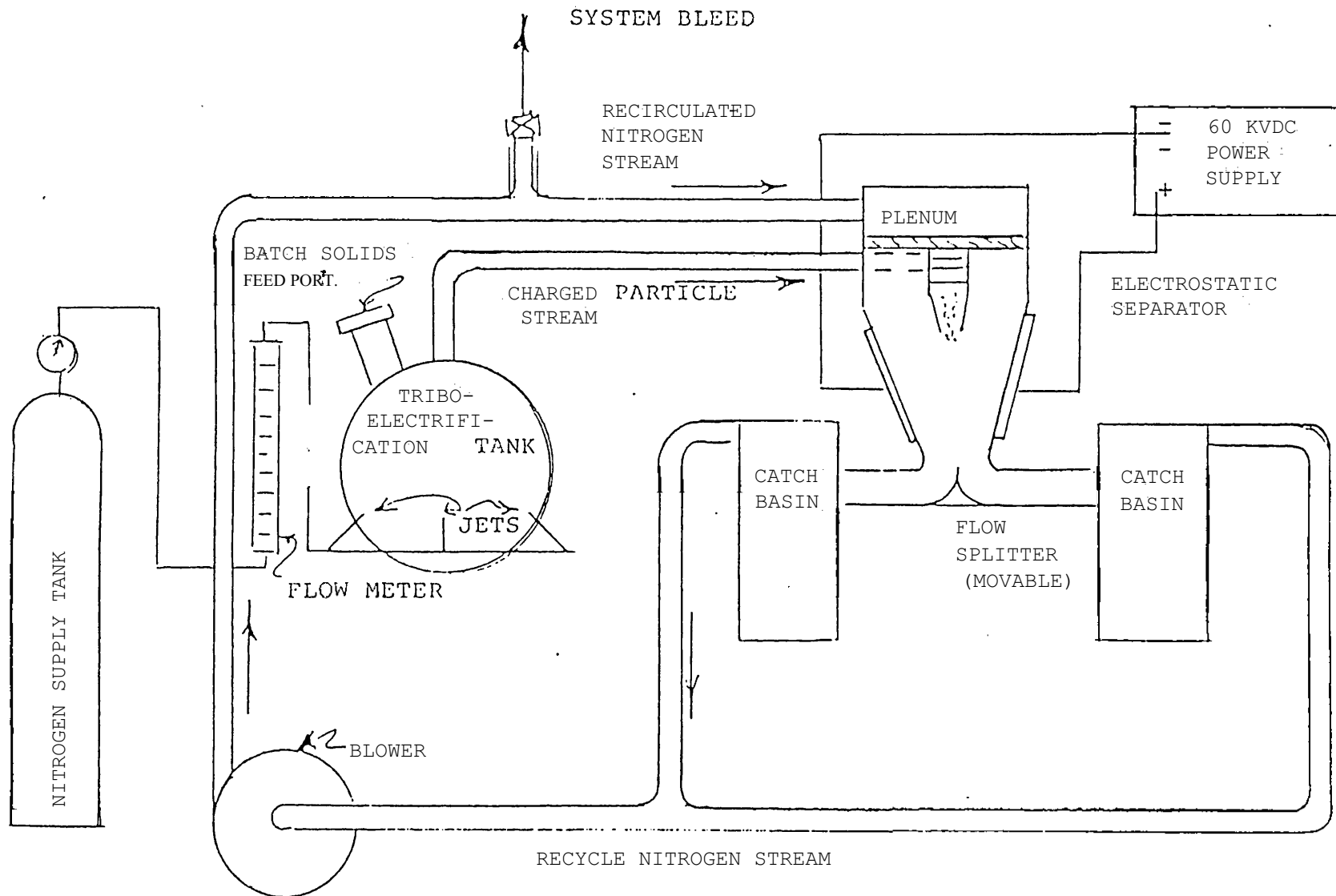

FIGURE 6. CONCEPT SKETCH FOR ELECTROSTATIC SEPARATION LABORATORY SCALE APPARATUS

### 3 .0 OBJECTIVE

The major objective of this research project was to evaluate a laboratory scale apparatus for separating ultrafine grind minerals from low-rank coals utilizing differences in the electrostatic properties of the organic/inorganic components. The laboratory scale apparatus will allow definition of a process and identify readily measurable characteristics of low-rank coals which could be cleaned successfully by this method.

### 4 .0 DETAILED DESIGN OF THE APPARATUS

The detailed design for a laboratory scale apparatus was completed and reported [29].

Details for construction of the apparatus are presented as a sketch in Figure 7. The use of plexiglas as the fabricating material allows flow visualization studies to be made as well as providing for insulation for the high voltage plates.

A sketch of the complete assembly is presented as Figure 8. The oxygen level meter was installed in the test section plenum so as to provide warning if the oxygen level should rise above about 5 percent. This should prevent any explosions in the apparatus due to arcing of the charged plates. The breakdown voltage gradient is approximately 19 kvdc per inch in air. The closest that the charged plates come together is 4 inches.



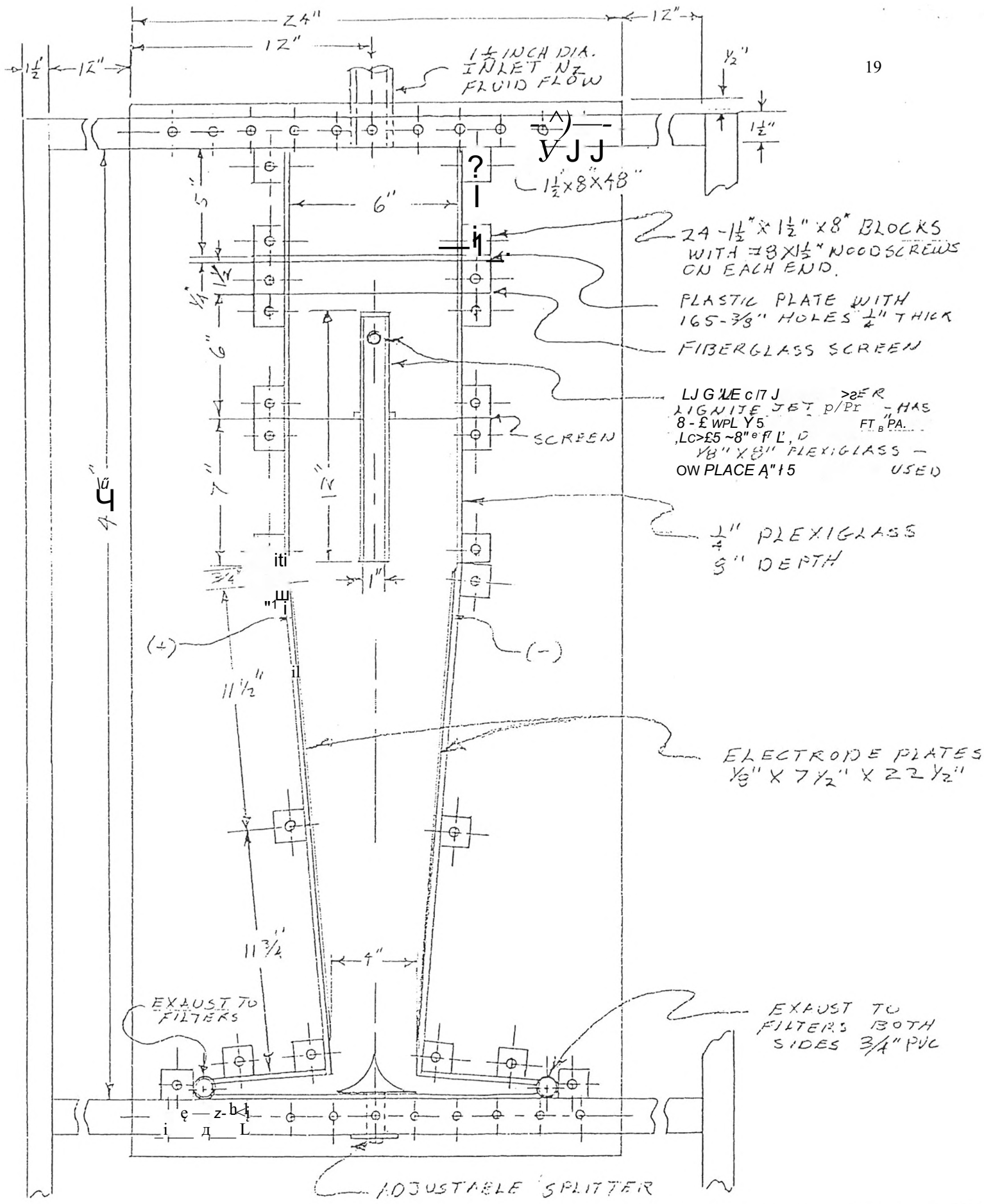

Figure 7. Cross Section Detail Sketch for Electronic Separator

ELECTROSTATIC TEST SECTION (F.V.)

LyEA f/JJ & II S.A' /i

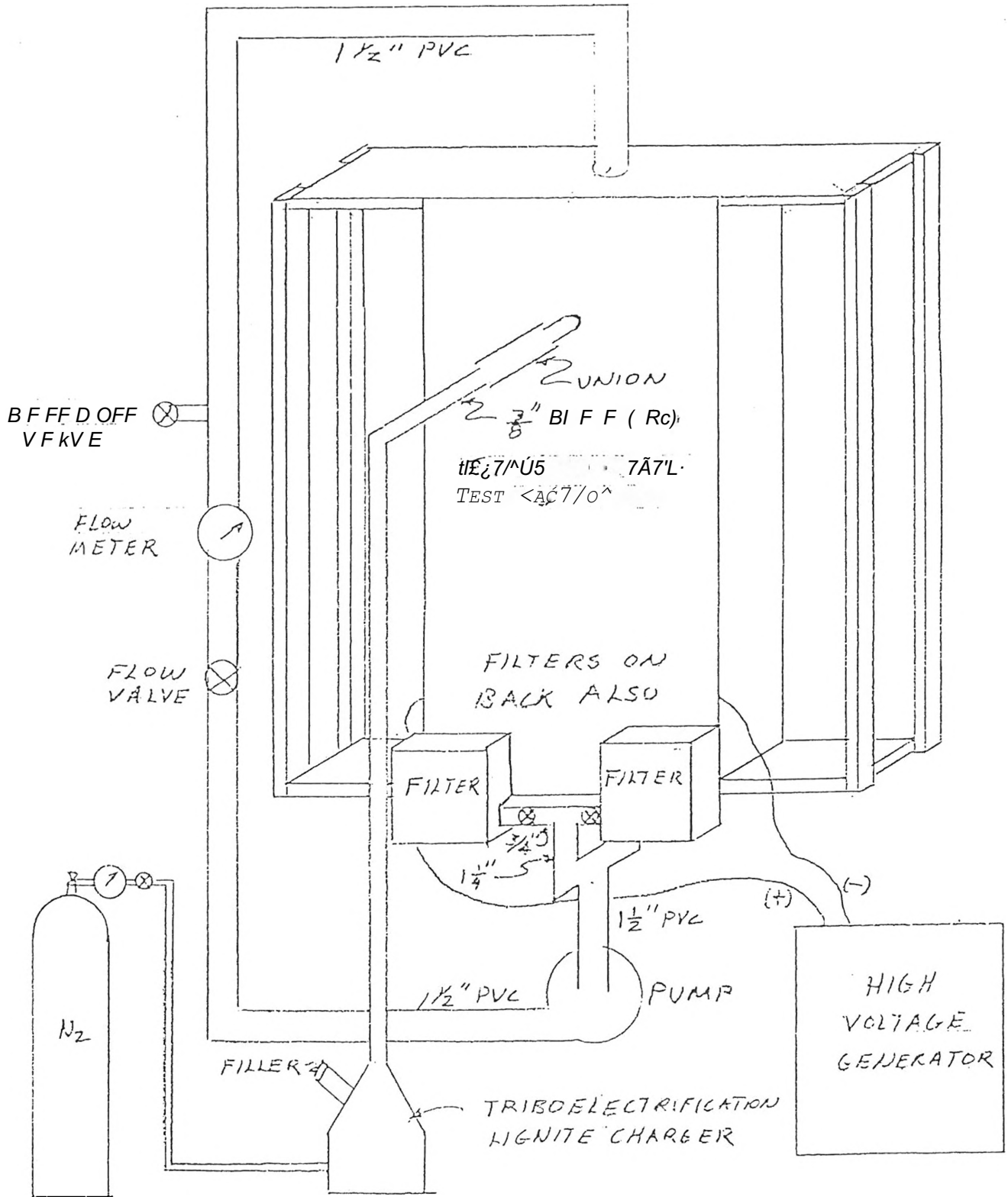

Figure 8. Sketch of Electrostatic Separator System

f A R C 7 R O F T A ^ ! / ^  
S R P F F A 7 O R  
DRAWN BY S. W. H.

## 5 .0 EXPERIMENTAL EVALUATION

Initial tests of the laboratory scale apparatus were unsuccessful because of the delay in the use of the ultrafine grind lignite particles. The particles came to electrostatic equilibrium during storage.

A mechanical agitator using a variable speed electric motor controlled by a variac has been designed, fabricated and installed in the mixing chamber.

Tests will be made using the modified triboelectrification apparatus and reported on later.

## 6 .0 CONCLUSIONS AND RECOMMENDATIONS

### 6.1 Conclusions

6.1.1 Triboelectrification of particles has been observed in the ultrafinely ground product from the fluid energy mill.

6.1.2 Particles will discharge in storage.

6.1.3 Further mechanical agitation is needed.

### 6.2 Recommendations

6.2.1 Complete the laboratory scale tests.

6.2.2 Design and fabricate full scale apparatus to be installed on a fluid energy mill.

6.2.3 Conduct experimental evaluation of the full scale apparatus.

## 7 .0 REFERENCES

1. Gronhovd, G. D., Sondreal, E. A., Lotowski, J. and Wiltsee, G., Low-Rank Coal Technology-Lignite and Subbituminous, Noyes Data Corp., Park Ridge, NJ, 1982.
2. Novácki, P., ed., Lignite Technology, Noyes Data Corporation, Park Ridge, NJ, 1980.
3. White, D. M., Kaiser, W. R. and Groat, C. G., "Status of Gulf Coast Lignite Activity," in Proceedings of the Eleventh Biennial Lignite Symposium, GFETC/IC-82-1, San Antonio, TX, June 15-17, 1981 .
4. Margulies, A. E., Moore, G. F. and West, R. J., "Ultrafine Pulverized Coal as an Alternate Fuel for Oil and Gas Fired Boilers," presented at the 9th Energy Technology Conference, Washington, DC, February, 1982.
5. West, R. J., Haider, G., Morris, T. A., Margulies, A. E. and Moore, G. F. , "Potential of Micronized Coal as an Alternate Fuel in Oil- and Gas-Fired Boilers," presented at the International Symposium on Conversion to Solid Fuels, Newport Beach, CA, October 26-28, 1982.
6. , "Ash Deposition Research on Canadian Lignites," Combustion Engineering, Inc., Windsor, CT (private communication from N. McLean, July, 1983).
7. Barsin, J. A., "Commercialization of Coal-Water Slurries,!.," presented at the 9th Energy Technology Conference, Washington, DC, February 1982.
8. Barsin, J., "Commercialization of Coal Water Slurries, II.," presented at the International Symposium on Conversion to Solid Fuel, Newport Beach, CA, October 26-28, 1982.
9. Pan, Y. S., Bellas, G. T., Snedden, R. B. and Joubert, J. I., "Coal Slurries as Alternate Fuels for Oil Designed Boilers," presented at the International Symposium on Conversion to Solid Fuel, Newport Beach, CA, October 26-28, 1982.
10. Kowalczewski, J. J., Bandopadhyay, P. D., Downie, R. J. and Read, W. R., "Ultrafine Grinding of Australian Brown Coal for Use in Diesel Engines," presented at the the Fifth International Symposium on Coal Slurry Combustion and Technology, Tampa, FL, April 25-27, 1983.
11. Savage, R. L., Warfield, W. R., Mengon, A. M. and Zronek, S. C., "Coal Slurry Utilization in Small Industrial Fire Tube Boilers," presented at the Fifth International Symposium on Coal Slurry Combustion and Technology, Tampa, FL, April 25-27, 1983.

12. Taylor, D. W., "Communitation of Pulverulent Material by Fluid Energy," U. S. Patent No. 4,219,164, August 26, 1 980.
13. Stanmore, B., Baria, D. N. and Paulson, L. E., "Steam Drying of Lignite: A Review of Processes and Performance, Report No. DOE/GFETC/RI-82/1, Grand Forks Energy Technology Center, Grand Forks, ND, 1982.
14. Baria, D. N., Maas, D. J. and Paulson, L. E., "Steam/Hot Water Drying of Lignite-Part 1 : Activities at the University of North Dakota Hot-Water Drying of Lignite to Produce Slurries," presented at the Twelfth Biennial Lignite Symposium, Grand Forks, ND, May 18-19, 1983.
15. White, D. M., "Overview of Mississippi Lignites as a Power Source for Electricity Generation," Seminar on Mississippi Lignite and Petroleum Resources, Jackson, MS, May 18-19, 1982.
16. Keller, D. V. and Simmons, F. J., "Heavy Liquid Beneficiation of Fine Coal," (DE83013822) DOE/PC/301 9-T3, OTISCA Industries, Ltd., 1 983.
17. Cavallaro, J. A. and Baker, A. F., "Washability Characteristics of Arkansas and Texas Lignites: Report of Investigations," DOE-EPA Interagency Energy/Environment Report-EPA-600/7-79-149, June 1979, or PMTC-5(79), Pittsburgh, PA, 1979.
18. Paulson, L. E., and Baria, D. N., "Conceptual Designs and Cost Estimates for Using Ion-Exchange to Reduce Ash Fouling in Combustion of Low-Rank Coal," presented at the American Institute of Chemical Engineers National Meeting, Anaheim, CA, June 7-10, 1982.
19. Steele, W. G., Bouchillon, C. W., Clippard, J. A. and Hartness, J. L. , "Evaluation of the Micropulverization of Mississippi Lignite," presented at the Twelfth Biennial International Meeting on Technology and Utilization of Low-Rank Coals, Grand Forks, ND, May 18-19, 1982.
20. Bouchillon, C. W., Steele, W. G., Clippard, J. A. and Burnett, J. D., "Evaluation of the Micropulverization, Drying and Beneficiation of Lignite," presented at the 6th International Coal and Lignite Utilization Exhibition and Conference, Houston, TX, November 15-17, 1983.
21. Bouchillon, C. W. and Steele, W. G., "Ultrafine Grinding of Low Rank Coal - Final Report - Phase I - Experimental Evaluation of Simultaneous Grinding and Drying of a Martin Lake, Texas Lignite," USDOE Contract No. AC21-84FC10622, August 1986.
22. Abel, William T., Zulkoski, Michael, and Gauntlett, Galen J., "Dry Separation of Pyrite from Coal," Ind. Eng. Chern. Prod. Res. Develop., Vol. 11, N. 3, 1972, p. 342.

23. Luborsky, F. E., "High Gradient Magnetic Separation for Removal of Sulfur from Coal," Final Report, Contract No. HO366008, Bureau of Mines, U. S. Dept, of Interior, Pittsburgh, PA, February 1977.
24. Schlomann, Ernst, "Separation of Non-magnetic Metals from Solid Waste by Permanent Magnets, I. Theory, and II. Experiments on Circular Disks," Journal of Applied Physiucs, Vol. 46, No. 11, November 1975, p. 5012.
25. Inculet, R. M., Quigley, R. M., Gergougou, M. A., Brown, J. D. , and Faurschou, D. K., "Electrostatic Beneficiation of Hat Creek Coal in the Fluidized State," CIM Bulletin, October, 1980, pp. 51-61 .
26. Bouchillon, C. W., Particle Trajectories in a Hydrocyclone, Ph.D. Dissertation, Georgia Institute of Technology, Atlanta, GA, May 1 963.
27. Boysan, F., Ayers, W. H., and Switherbank, J., "A Fundamental Mathematical Modelling Approach to Cyclone Design," Trans. I. Chem. E., Vol. 60, 1982, p. 222.
28. Nester, Willie J. and Bouchillon, C. W., "Preliminary Design of an Electrostatic Separator for Micropulverized Lignite," Report No. MSU-EIRS-M&NE-85-1, Mississippi State University, July 1985.
29. Bouchillon, C. W., Steele, W. G., and Henderson, W. S., "Detailed Design of an Electrostatic Separator on Ultrafine Grind Lignite," Final Report, MMRI Grant 86-4F under Bureau of Mines Allocation Grant No. G1 1 541 28, July, 1986.